

# Service Manual

Finisher, Sorter, DeliveryTray  
**Punch Unit-W1**

**Canon**



## Application

This manual has been issued by Canon Inc. for qualified persons to learn technical theory, installation, maintenance, and repair of products. This manual covers all localities where the products are sold. For this reason, there may be information in this manual that does not apply to your locality.

## Corrections

This manual may contain technical inaccuracies or typographical errors due to improvements or changes in products. When changes occur in applicable products or in the contents of this manual, Canon will release technical information as the need arises. In the event of major changes in the contents of this manual over a long or short period, Canon will issue a new edition of this manual.

The following paragraph does not apply to any countries where such provisions are inconsistent with local law.

## Trademarks

The product names and company names used in this manual are the registered trademarks of the individual companies.

## Copyright

This manual is copyrighted with all rights reserved. Under the copyright laws, this manual may not be copied, reproduced or translated into another language, in whole or in part, without the written consent of Canon Inc.

***COPYRIGHT © 2001 CANON INC.***

*Printed in Japan*

## Caution









Use of this manual should be strictly supervised to avoid disclosure of confidential information.

---

# Symbols Used



---

This documentation uses the following symbols to indicate special information:

Symbol	Description
	Indicates an item of a non-specific nature, possibly classified as Note, Caution, or Warning.
	Indicates an item requiring care to avoid electric shocks.
	Indicates an item requiring care to avoid combustion (fire).
	Indicates an item prohibiting disassembly to avoid electric shocks or problems.
	Indicates an item requiring disconnection of the power plug from the electric outlet.
 Memo	Indicates an item intended to provide notes assisting the understanding of the topic in question.
 REF.	Indicates an item of reference assisting the understanding of the topic in question.
	Provides a description of a service mode.
	Provides a description of the nature of an error indication.

The following rules apply throughout this Service Manual:

1. Each chapter contains sections explaining the purpose of specific functions and the relationship between electrical and mechanical systems with reference to the timing of operation.

In the diagrams,  represents the path of mechanical drive; where a signal name accompanies the symbol, the arrow  indicates the direction of the electric signal.

The expression "turn on the power" means flipping on the power switch, closing the front door, and closing the delivery unit door, which results in supplying the machine with power.

2. In the digital circuits, '1' is used to indicate that the voltage level of a given signal is "High", while '0' is used to indicate "Low". (The voltage value, however, differs from circuit to circuit.) In addition, the asterisk (\*) as in "DRMD\*" indicates that the DRMD signal goes on when '0'.

In practically all cases, the internal mechanisms of a microprocessor cannot be checked in the field. Therefore, the operations of the microprocessors used in the machines are not discussed: they are explained in terms of from sensors to the input of the DC controller PCB and from the output of the DC controller PCB to the loads.

The descriptions in this Service Manual are subject to change without notice for product improvement or other purposes, and major changes will be communicated in the form of Service Information bulletins.

All service persons are expected to have a good understanding of the contents of this Service Manual and all relevant Service Information bulletins and be able to identify and isolate faults in the machine."



---

# Contents

## Chapter 1 Specifications

1.1 Product Specifications .....	1- 1
1.1.1 Specifications .....	1- 1
1.2 Names of Parts .....	1- 2
1.2.1 Cross Section .....	1- 2

## Chapter 2 Functions

2.1 Basic Construction .....	2- 1
2.1.1 Overview .....	2- 1
2.2 Feed Drive System .....	2- 1
2.2.1 Overview .....	2- 1
2.2.2 Moving the Paper .....	2- 4
2.2.3 Punching Operation .....	2- 7
2.2.4 Checking the Condition of the Punch Chip Case .....	2- 9

## Chapter 3 Parts Replacement Procedure

3.1 Removing from the Host Machine .....	3- 1
3.1.1 Punch Unit .....	3- 1
3.1.1.1 Removing the Punch Unit .....	3- 1
3.2 External Covers .....	3- 2
3.2.1 Rear Lower Cover .....	3- 2
3.2.1.1 Before Removing the Lower Rear Cover .....	3- 2
3.2.1.2 Removing the Lower Rear Cover .....	3- 2
3.2.2 Rear Middle Cover .....	3- 2
3.2.2.1 Removing the Middle Rear Cover .....	3- 2
3.2.3 Inside Cover (Upper) .....	3- 2
3.2.3.1 Removing the Inside Cover (upper) .....	3- 2
3.3 Drive System .....	3- 2
3.3.1 Punch Motor .....	3- 2
3.3.1.1 Before Removing the Punch Motor .....	3- 2
3.3.1.2 Removing the Punch Motor .....	3- 2
3.4 Electrical System .....	3- 3
3.4.1 Scrap Full Detector PCB .....	3- 3
3.4.1.1 Removing the Punch Waste Case Full Sensor PCB .....	3- 3

## Chapter 4 Maintenance

4.1 User Maintenance .....	4- 1
4.1.1 User Maintenance Items .....	4- 1
4.2 Maintenance and Inspection .....	4- 1
4.2.1 Periodically Replaced Parts .....	4- 1
4.2.1.1 Periodically Replaced Parts .....	4- 1
4.2.2 Durables .....	4- 1
4.2.2.1 Durables .....	4- 1
4.2.3 Periodical Servicing .....	4- 1
4.2.3.1 Scheduled Servicing .....	4- 1
4.3 Adjustment .....	4- 2
4.3.1 Basic Adjustment .....	4- 2
4.3.1.1 Setting Up the Punching Operation .....	4- 2
4.3.1.2 Adjusting the Sensor Light Intensity .....	4- 2

4.3.1.3 Adjusting the Paper Stop Position .....	4- 3
4.3.2 Auxiliary Adjustmant .....	4- 4
4.3.2.1 Adjusting the Punch Hole Position (in the direction of horizontal registration).....	4- 4
4.3.2.2 Adjusting the Punch Hole Position (in the direction of paper movement) .....	4- 4

Chapter 5 Error Code

5.1 Overview .....	5- 1
5.1.1 Overview .....	5- 1
5.2 Service Error Code.....	5- 1
5.2.1 E503.....	5- 1
5.2.2 E590.....	5- 1



---

## Chapter 1 Specifications

---



# Contents

1.1 Product Specifications.....	1-1
1.1.1 Specifications.....	1-1
1.2 Names of Parts.....	1-2
1.2.1 Cross Section.....	1-2



# 1.1 Product Specifications

## 1.1.1 Specifications

T-1-1

Item	Description	Remarks
Punching method	reciprocating (consecutive processing)	
Paper size	2-hole (Punch Unit-U1): A3, A4, A4R, B4, B5, B5R 2-/3-hole (Punch Unit-V1): 2-hole/LGL, LTRR 3-hole/279mm x 432mm (11 x 17), LTR 4-hole (FR; Punch Unit-W1): A3, A4 4-hole (SE; Punch Unit-X1): A3, A4	
Paper weight	64g/m2 to 200g/m2	no transparency; no paper 200 g/m2 or more in weight
Punch hole diameter	2-hole: 6.5 mm 2-/3-hole: 8 mm 4-hole: 6.5 mm	
Punch chip case	equivalent of 5,000 sheets	equivalent of 80 g/m2 paper
Dimensions	78mm x 655mm x 131xmm (WxDxH)	
Weight	3 kg (approx.)	
Power supply	24/5 VDC from finisher	

### Hole Locations

[1]Puncher unit-U1(2-hole)

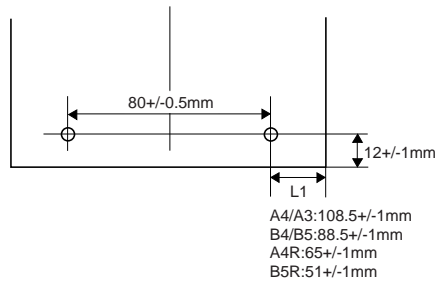

[3]Puncher unit-W1(4-hole; FR)

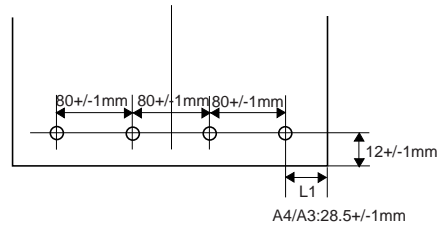

[2]Puncher unit-V1(2/3-hole)

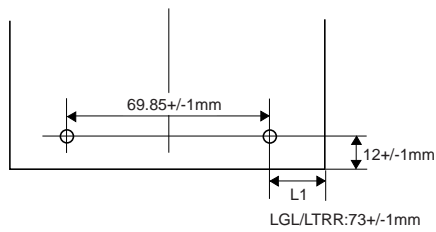

[4]Puncher unit-X1(4-hole; SE)

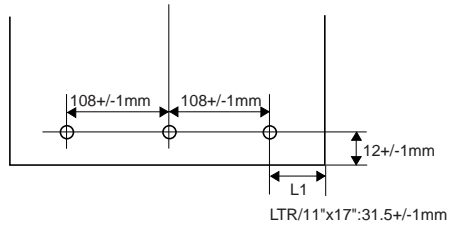
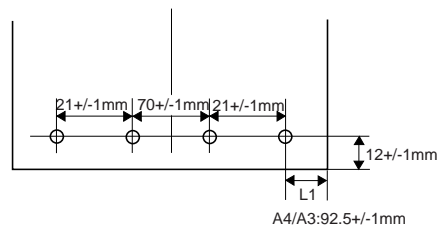

F-1-1

## 1.2 Names of Parts

### 1.2.1 Cross Section

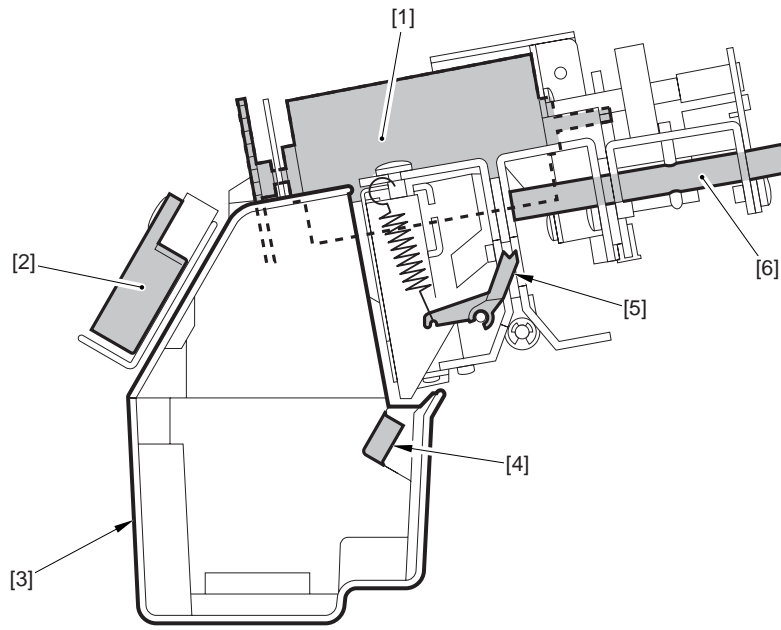

- [1] Punch Motor
- [2] Punch chip case full sensor
- [3] Punch chip case
- [4] Prism
- [5] Stopper
- [6] Pin

---

## Chapter 2 Functions

---





# Contents

2.1 Basic Construction .....	2-1
2.1.1 Overview .....	2-1
2.2 Feed Drive System .....	2-1
2.2.1 Overview .....	2-1
2.2.2 Moving the Paper .....	2-4
2.2.3 Punching Operation .....	2-7
2.2.4 Checking the Condition of the Punch Chip Case .....	2-9



## 2.1 Basic Construction

### 2.1.1 Overview

The machine is fitted in the paper path of a finisher.

When paper arrives from the host machine, the shift roller starts to move it ahead; the shift transport motor then moves the paper back to the puncher unit and forces its trail edge against the stopper to remove the skew to prepare for punching operation.

The finisher controller PCB is used to drive the punch unit.

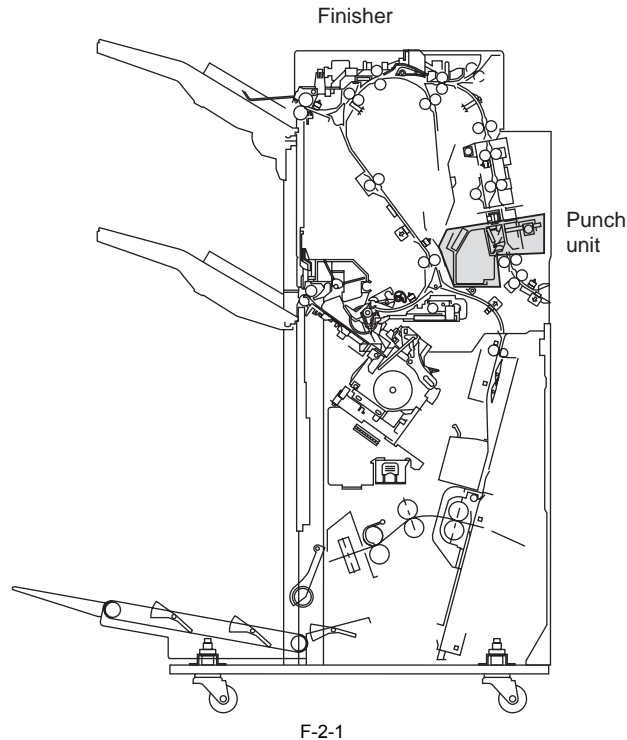

## 2.2 Feed Drive System

### 2.2.1 Overview

The machine punches holes in paper when the paper has been stacked in the finisher and stopped.

When paper arrives from the host machine, the shift roller starts to move it ahead; the shift transport motor then moves the paper back to the puncher unit and forces its trail edge against the stopper to remove the skew to prepare for punching operation.

The punch unit operates a slider using the drive of the punch motor (M24), and moves the punch along the slit made in the slider.

A single punching operation ends when the slider completes movement of a specific distance, and the slider is being monitored by the punch front sensor (PS37). Punching is executed in response to the state (on/off) of the inlet sensor.

The chips occurring as the result of punching are collected in the punch chip case, which is monitored by a reflection type sensor for identification of a full state. The following shows the motors and sensors used for punching operation:

T-2-1

Motor	Description
Punch motor (M24)	Drives the punch slider

T-2-2

Sensor	Description
Punch 2/3-hole sensor (PS39)	Detects the slider 2/3-hole position of the slider
Punch clock sensor (PS38)	Monitors the speed of punch motor rotation and timing at which the slider movement is stopped
Punch motor home position sensor (PS36)	Detects the slider position
Punch front sensor (PS37)	Detects the slider front/rear position
Punch chip case sensor (PS40)	Detects the presence/absence of the punch chip case
Punch chip case full sensor	Monitors the state (full) of the punch chip case

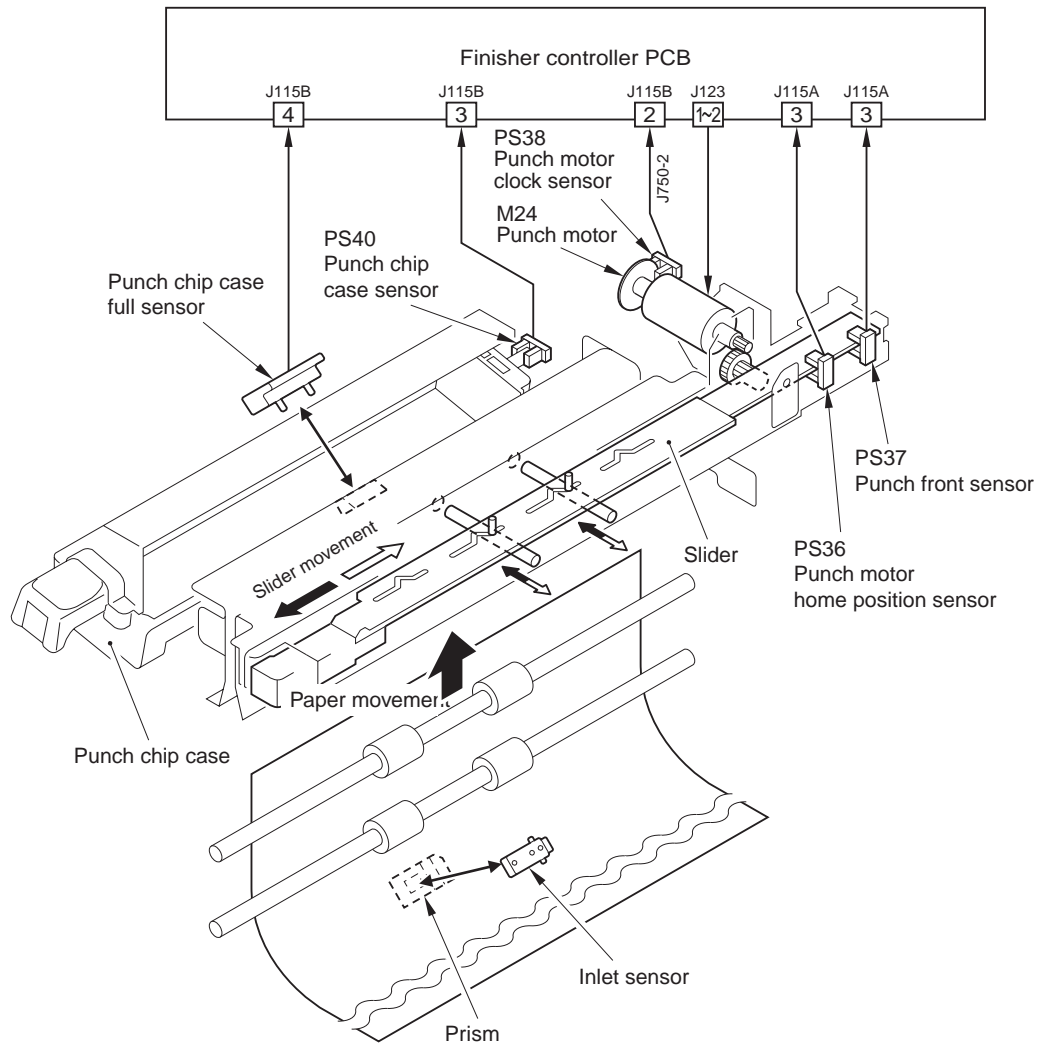

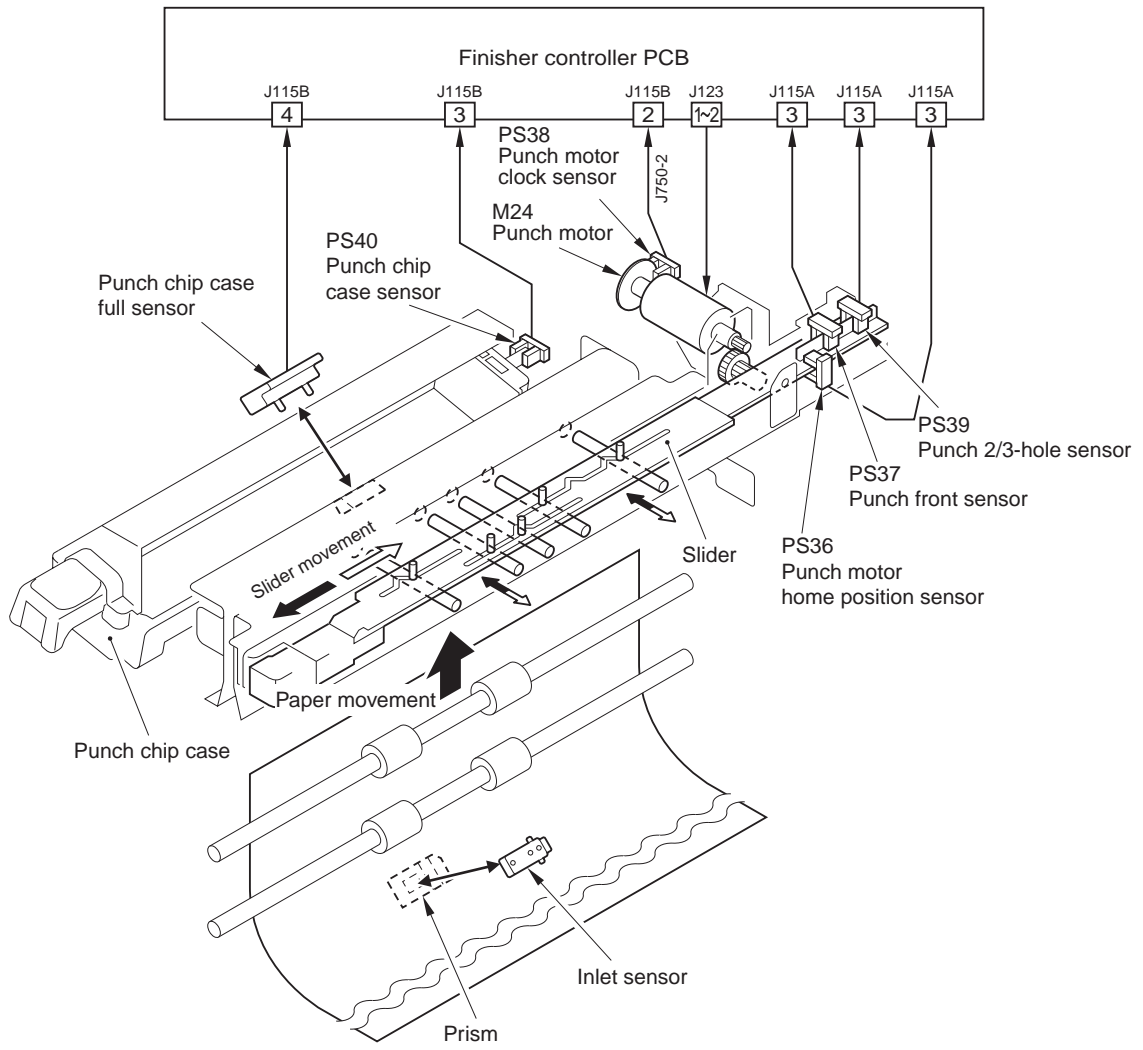

F-2-3

### 2.2.2 Moving the Paper

Inside the machine, paper is moved as follows:

- 1) When the inlet sensor (PS3) detects the lead edge of paper, the horizontal registration detection unit shift motor (M6) goes on to move the horizontal registration detection unit to the point of paper detection.

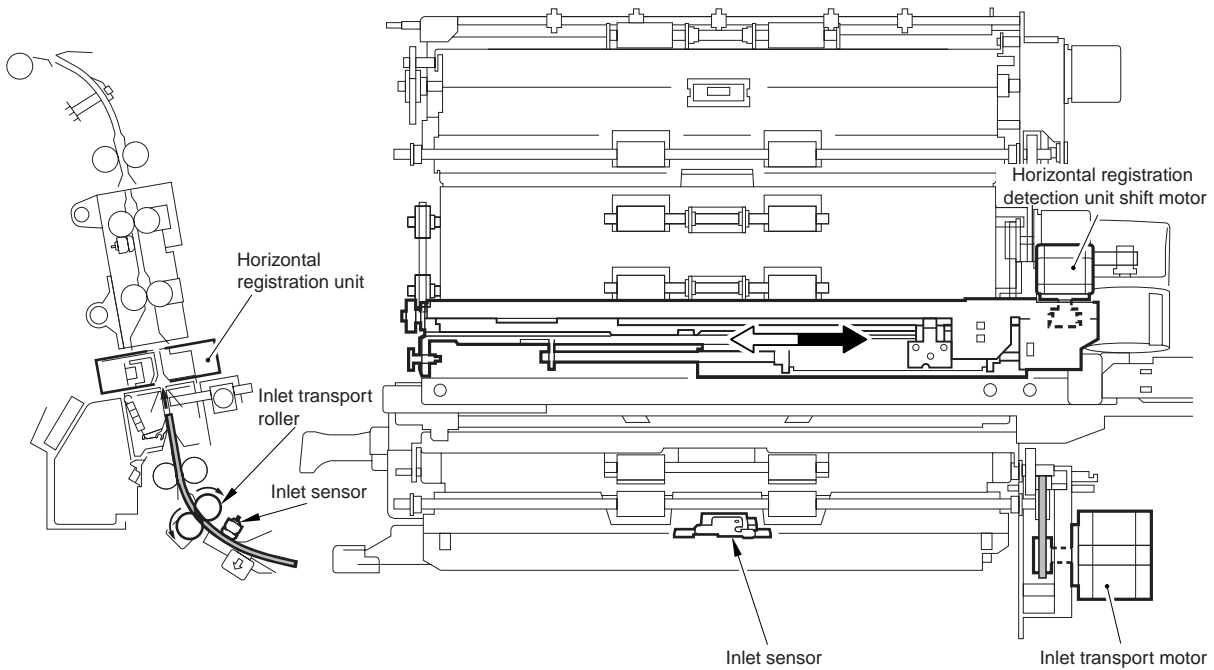

F-2-4

- 2) When the inlet sensor detects the lead edge of paper, the machine moves the paper over a specific distance and then uses the shift transport motor to drive the shift roller.

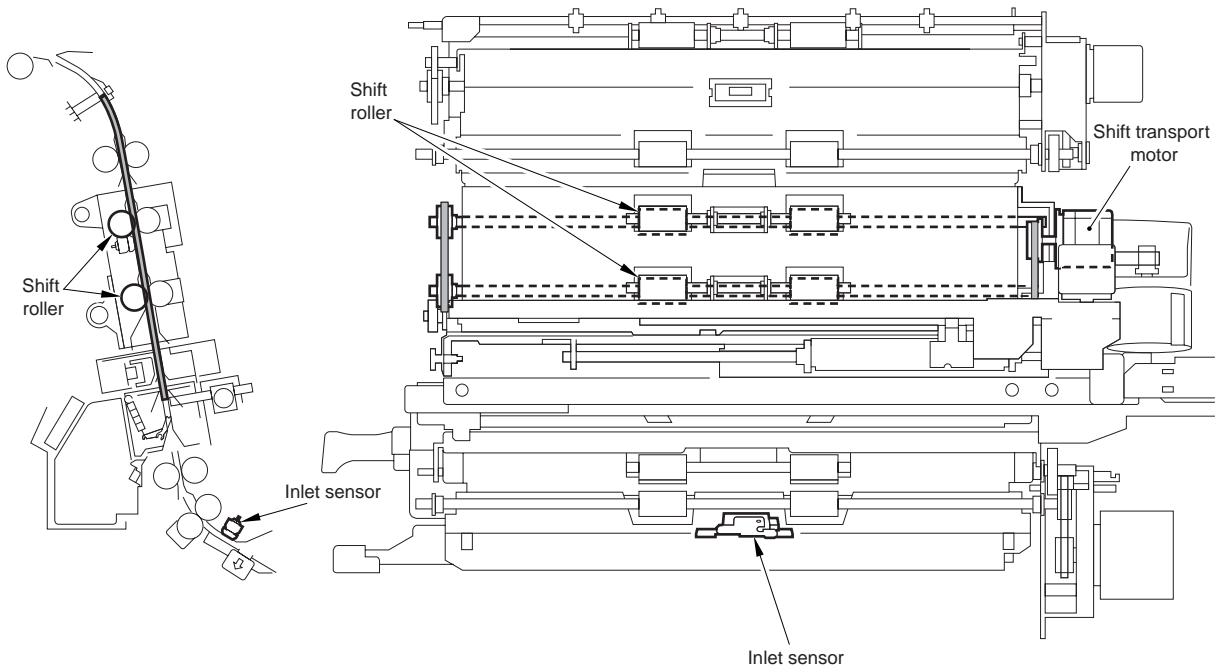

F-2-5

- 3) With paper remaining in contact with the shift roller, the horizontal shift motor goes on to move the shift roller unit for correction of displacement in horizontal direction.

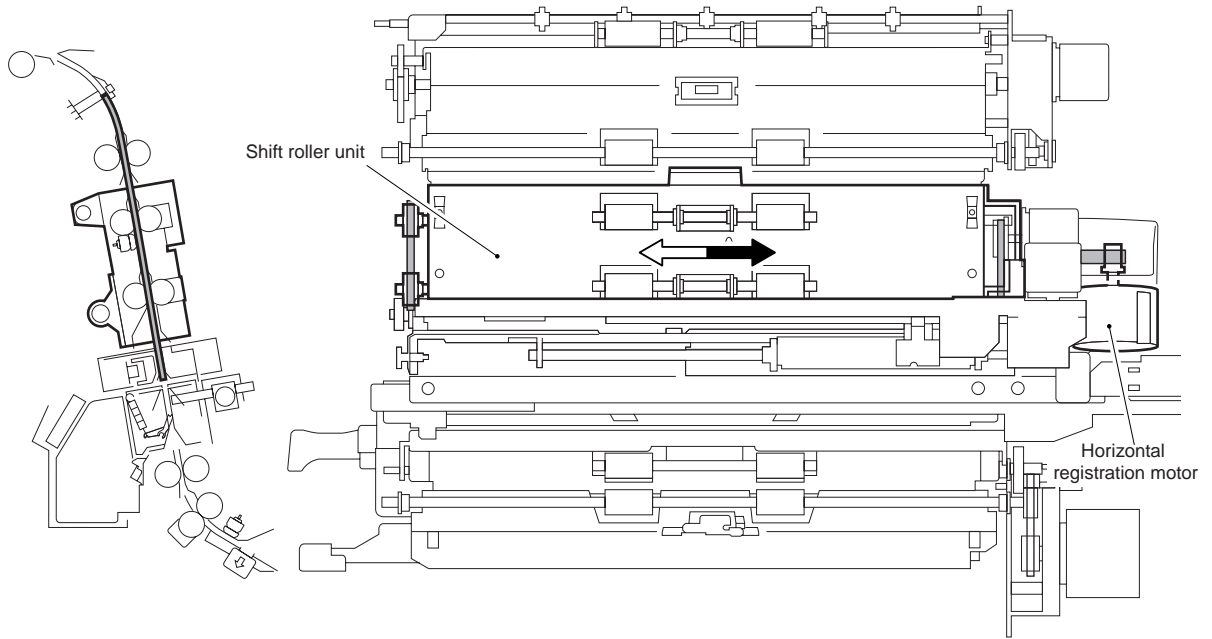

F-2-6

4) After correcting displacement in horizontal registration, the machine uses the shift transport motor to move the paper back to the punch unit and, at the same time, executes full horizontal registration, in which the edge of the paper hits the stopper mounted to the punch unit. The machine is now ready for punching.

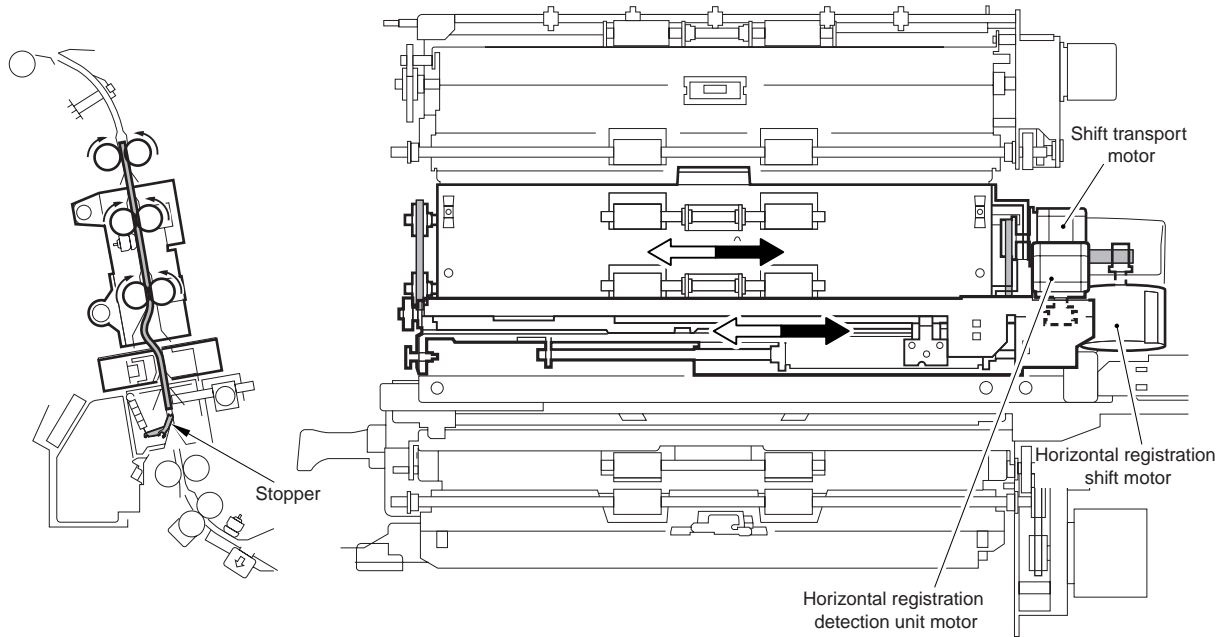

F-2-7

5) At the end of punching, the machine uses the shift roller for delivery of the paper.

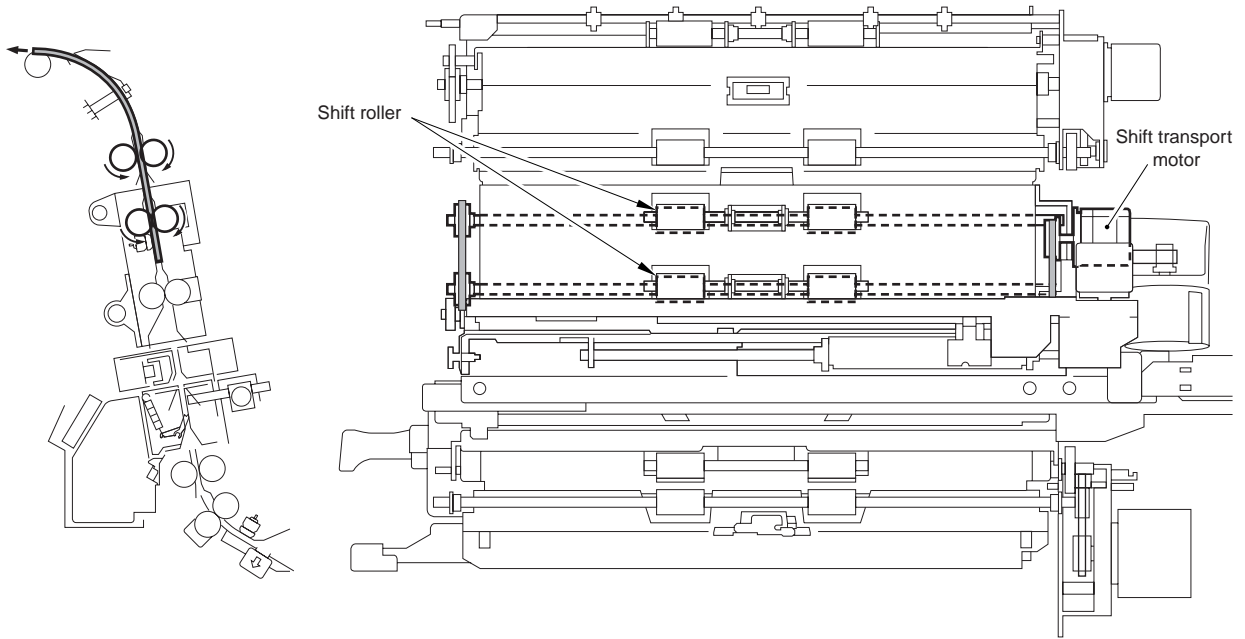

F-2-8



### 2.2.3 Punching Operation

The machine executes punching operation with reference to the state (on/off) of the inlet sensor.

When the power is turned on or when a job is started, the machine moves the slider to its home position.

The shift transport motor moves the paper back to the punch unit and forces its edge against the stopper mounted to the punch unit for removal of the skew.

Thereafter, the machine uses the punch motor (M24) to drive the slider, initiating punching operation along the slit made in the slider.

A single punching operation ends when the slider moves over a specific distance. The position of the slider is monitored by the punch front sensor (PS37) and the punch motor home position sensor (PS36).

The speed of rotation of the punch motor and the timing at which the slider is stopped are monitored by the punch motor clock sensor (PS38).

For 2/3-hole punching operation, the machine uses the punch motor to move the slider back and forth, with the punch 2/3-hole sensor (PS39), punch front sensor (PS37), and punch motor home position sensor (PS36) detecting its position.

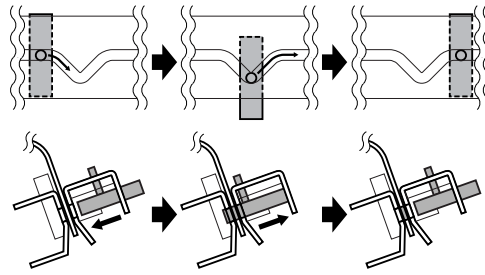
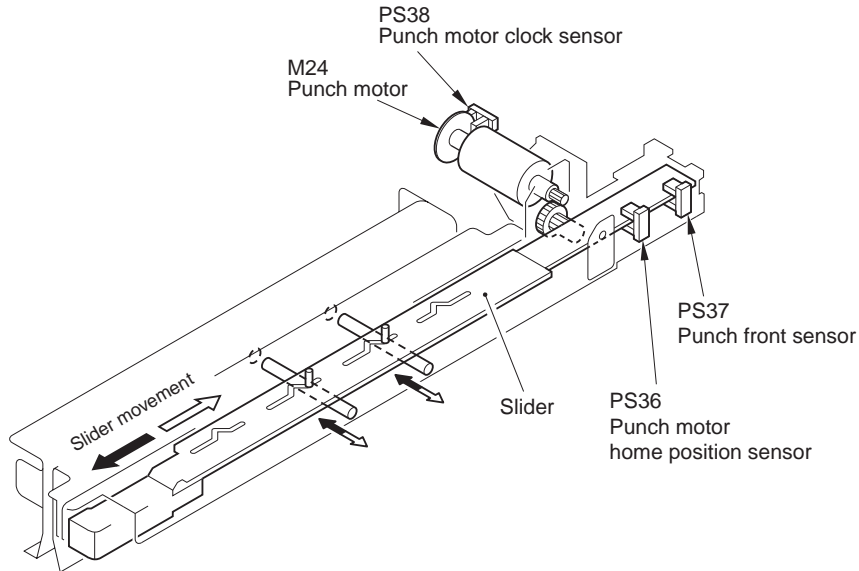

F-2-9

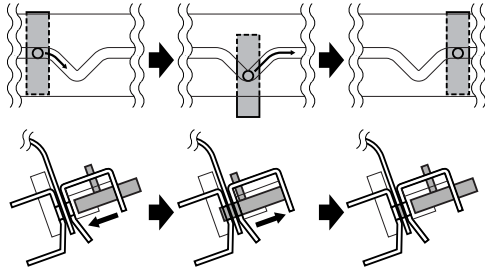
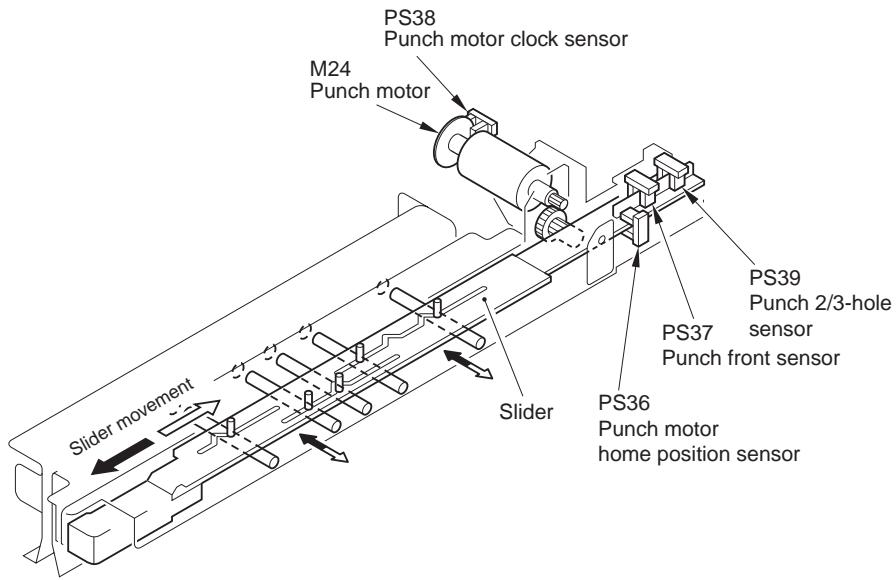

F-2-10

### 2.2.4 Checking the Condition of the Punch Chip Case

The punch chip case detection mechanism consists of the punch chip case full sensor mounted to the side of the punch chip case and a prism found inside the case. The punch chip case sensor, on the other hand, is used to check the presence/absence of the punch chip case.

The chips occurring as the result of punching operation are collected in the punch chip case, and are monitored by a reflection type sensor (punch chip case full sensor). When the case becomes full with chips, the main controller PCB suspends punching operation between stacks (Memo), resuming the operation when the case is put back in place.

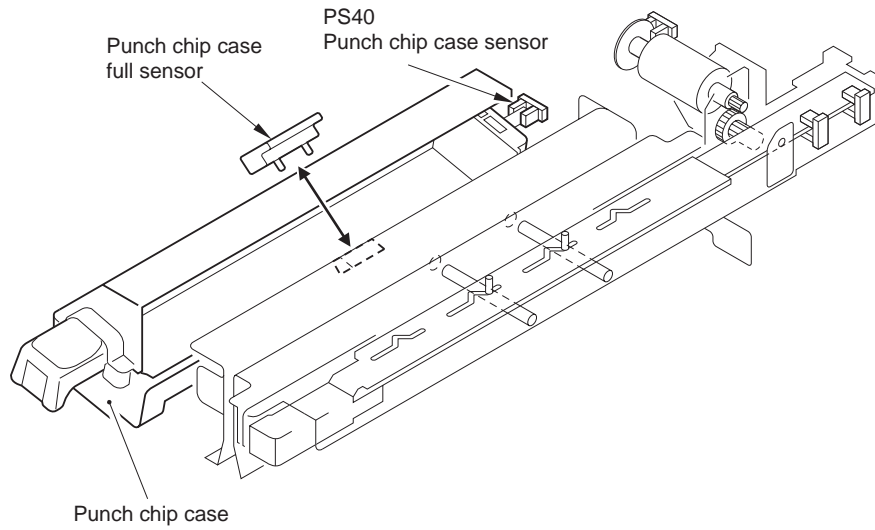

F-2-11

**MEMO:**

If the punch chip case is found to be full when the 2nd sheet of the 3rd set is being handled while making 5 sets of 5 copies, the machine continues to operate until the 3rd set is complete, suspending its operation at the start of the 4th set.



---

## Chapter 3 Parts Replacement Procedure

---



---

# Contents

3.1 Removing from the Host Machine.....	3-1
3.1.1 Punch Unit .....	3-1
3.1.1.1 Removing the Punch Unit .....	3-1
3.2 External Covers.....	3-2
3.2.1 Rear Lower Cover .....	3-2
3.2.1.1 Before Removing the Lower Rear Cover.....	3-2
3.2.1.2 Removing the Lower Rear Cover .....	3-2
3.2.2 Rear Middle Cover.....	3-2
3.2.2.1 Removing the Middle Rear Cover .....	3-2
3.2.3 Inside Cover (Upper) .....	3-2
3.2.3.1 Removing the Inside Cover (upper).....	3-2
3.3 Drive System.....	3-2
3.3.1 Punch Motor.....	3-2
3.3.1.1 Before Removing the Punch Motor .....	3-2
3.3.1.2 Removing the Punch Motor .....	3-2
3.4 Electrical System.....	3-3
3.4.1 Scrap Full Detector PCB.....	3-3
3.4.1.1 Removing the Punch Waste Case Full Sensor PCB.....	3-3





## 3.1 Removing from the Host Machine

### 3.1.1 Punch Unit

#### 3.1.1.1 Removing the Punch Unit

- 1) Open the finisher's front cover.
- 2) Slide out the punch waste case [1] to detach.

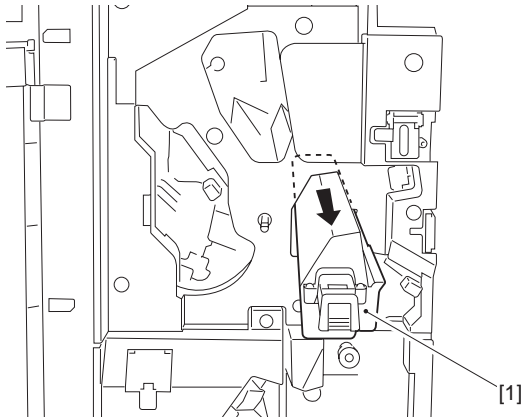

F-3-1

- 3) Remove the rear middle cover [1].  
- 4 screws [2]

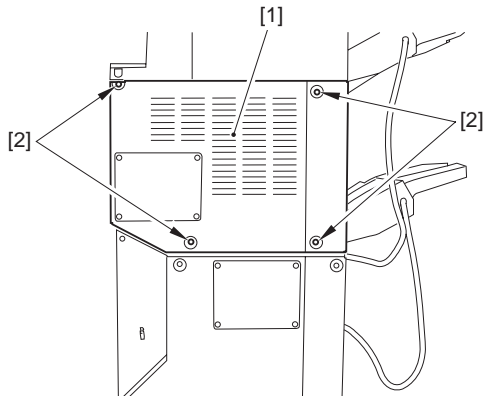

F-3-2

- 4) Remove the lower rear cover [1].  
- 8 screws [2]

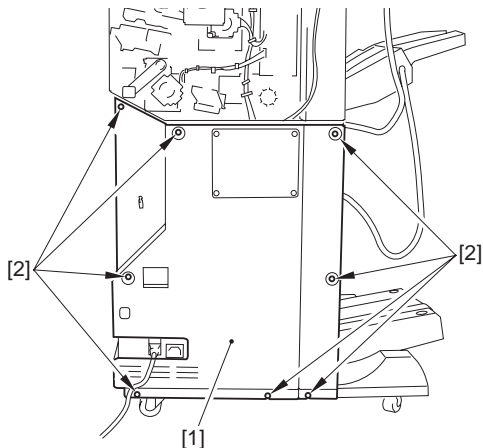

F-3-3

- 5) Disconnect the 2 connectors [2] from the finisher controller [1]; then, free the cable from the cable clamp [3].

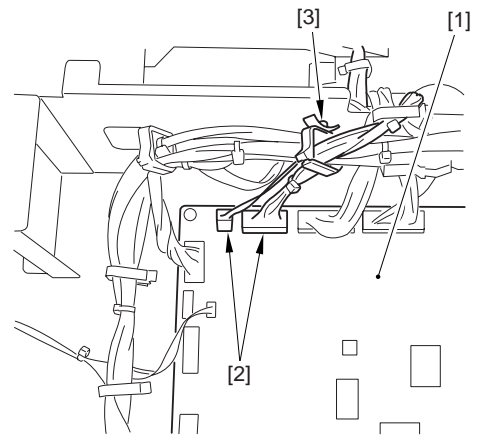

F-3-4

- 6) Free the cable [1].  
- 3 cable clamps [2]  
- cable guide [3]
- 7) Disconnect the connector [4] coming from the punch case full sensor unit from the connector [5] of the punch unit.

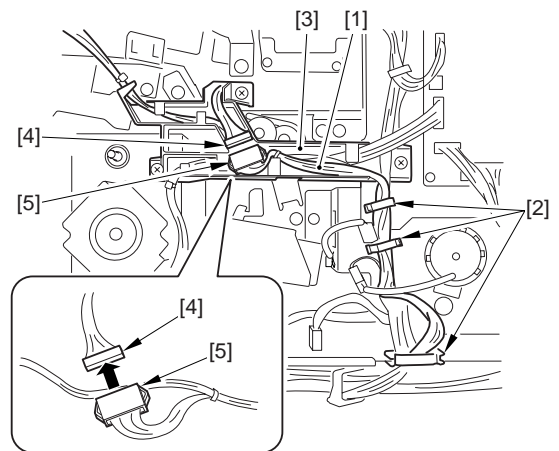

F-3-5

- 8) Remove the screw [2] of the latch base (rear) [1]; then, shift it toward the front.

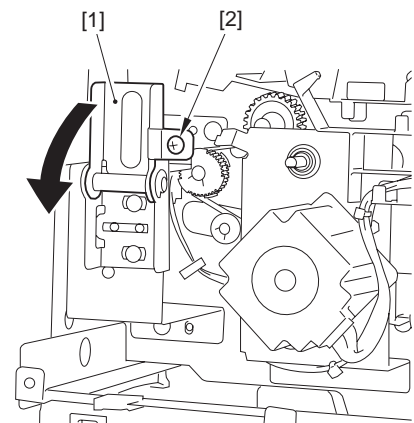

F-3-6

- 9) Remove the punch unit [1].  
- 2 screws [2]

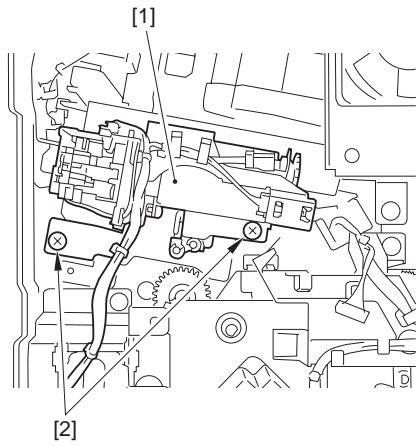

F-3-7

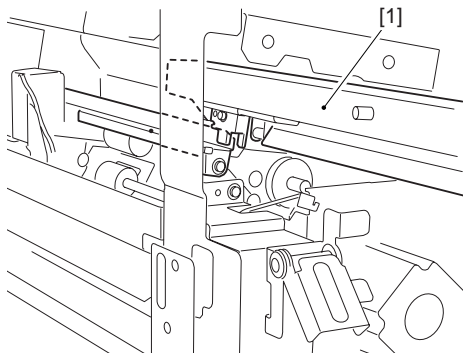

F-3-8

## 3.2 External Covers

### 3.2.1 Rear Lower Cover

#### 3.2.1.1 Before Removing the Lower Rear Cover

- 1) Remove the middle rear cover. (page 3-2)Reference[Removing the Middle Rear Cover]

#### 3.2.1.2 Removing the Lower Rear Cover

- 1) Remove the middle rear cover.  
- 8 screws [2]

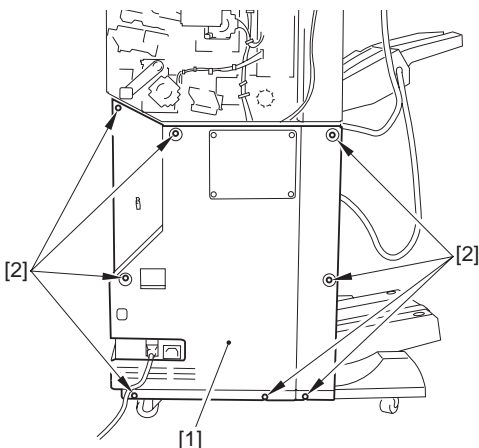

F-3-9

### 3.2.2 Rear Middle Cover

#### 3.2.2.1 Removing the Middle Rear Cover

- 1) Remove the middle rear cover [1].  
- 4 screws [2]

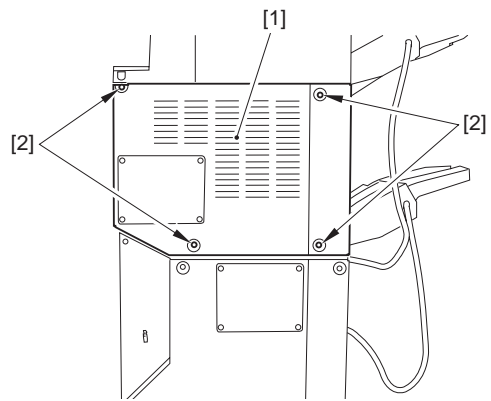

F-3-10

### 3.2.3 Inside Cover (Upper)

#### 3.2.3.1 Removing the Inside Cover (upper)

- 1) Open the finisher's front cover.
- 2) Remove the knob [1] from the inside cover (upper).

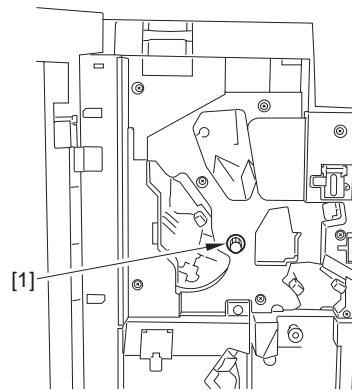

F-3-11

- 3) Lift the upper cover [1], and remove the inside cover (upper) [2].  
- 8 screws [3]

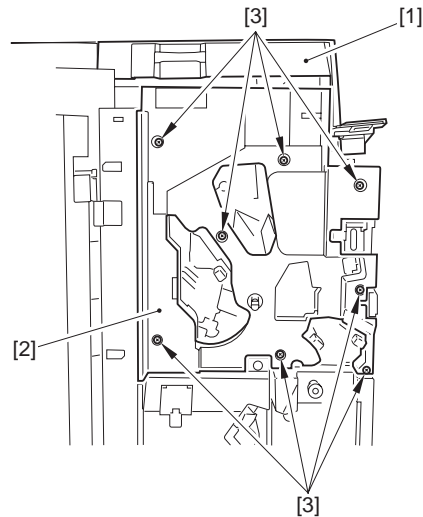

F-3-12

## 3.3 Drive System

### 3.3.1 Punch Motor

#### 3.3.1.1 Before Removing the Punch Motor

- 1) Remove the punch unit. (page 3-1)Reference[Removing the Punch Unit]

#### 3.3.1.2 Removing the Punch Motor

- 1) Disconnect the 2 connectors [1].

- 2 cables [2]
- 2 cable retainers [3]

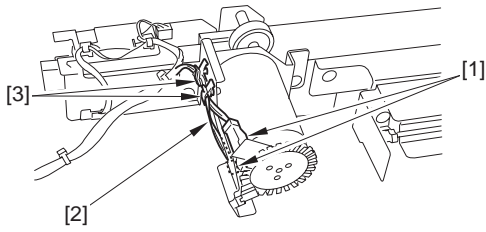

F-3-13

- 2) Remove the punch gear unit [1].
- 2 screws [2]

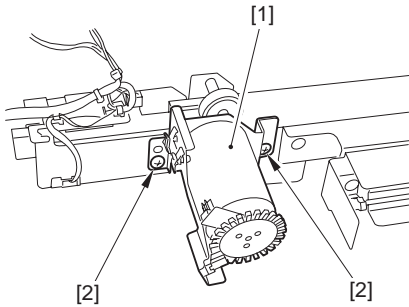

F-3-14

- 3) Remove the gear [1].
- E-ring [2]

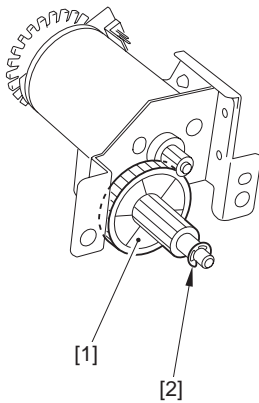

F-3-15

- 4) Remove the punch motor [1].
- 2 screws [2]

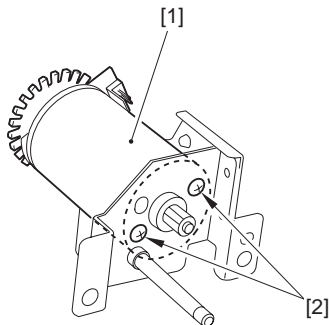

F-3-16

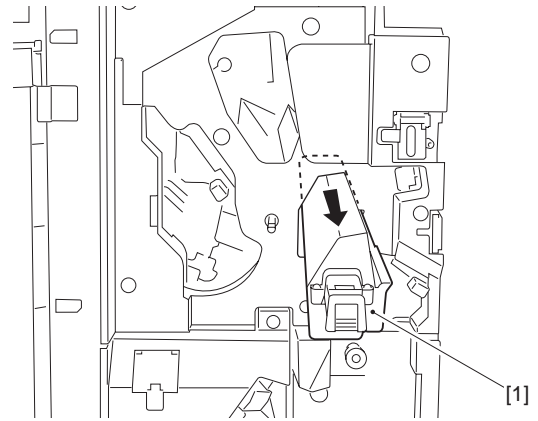

F-3-17

- 3) Remove the knob [1] from the inside cover (upper).

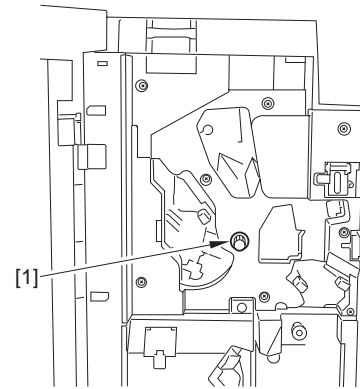

F-3-18

- 4) Lift the upper cover [1], and detach the inside over (upper) [2].
- 8 screws [3]

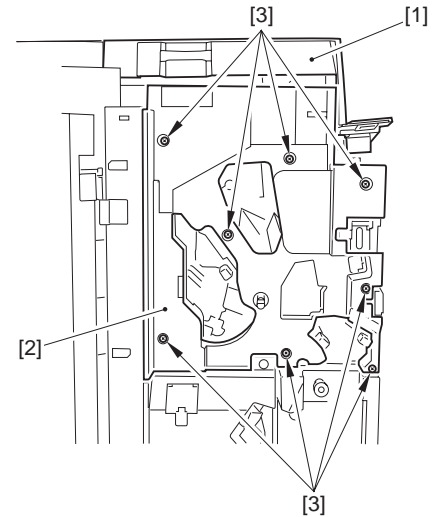

F-3-19

- 5) Remove the middle rear cover [1].
- 4 screws [2]

### 3.4 Electrical System

#### 3.4.1 Scrap Full Detector PCB

##### 3.4.1.1 Removing the Punch Waste Case Full Sensor PCB

- 1) Open the finisher's front cover.
- 2) Slide out the punch waste case [1] to detach.

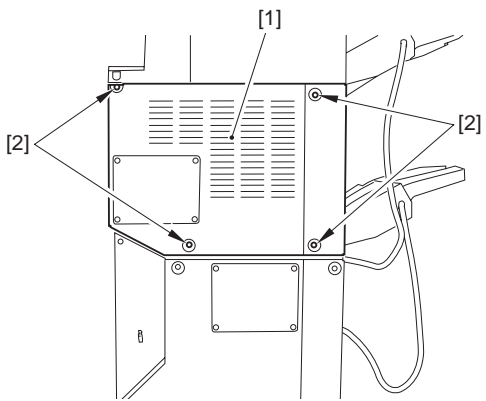

F-3-20

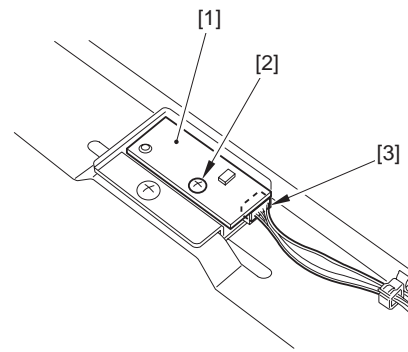

F-3-23

- 6) Disconnect the connector [1] coming from the punch waste case full sensor unit from the connector [2] of the punch unit.

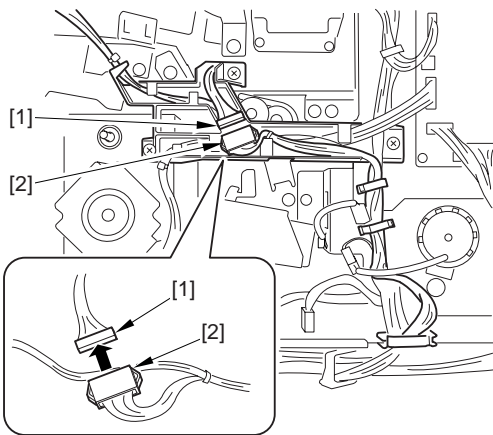

F-3-21

- 7) Free the cable [1] from the edge saddle [2], and detach the punch waste case full sensor unit [3] from the front side.  
- 1 screw [4]

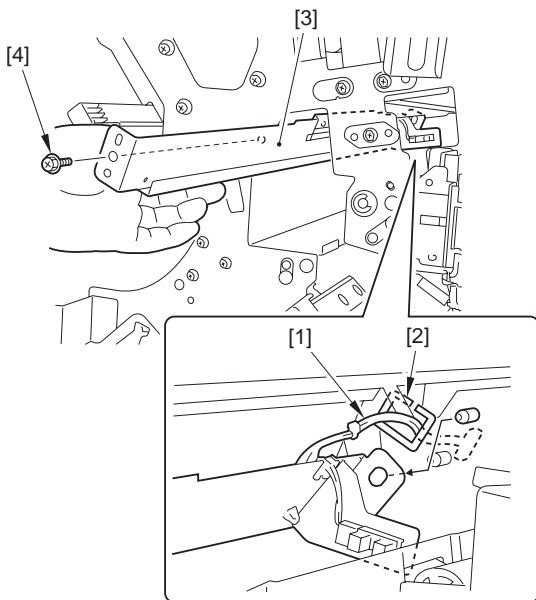

F-3-22

- 8) Detach the punch waste case full sensor PCB [1].  
- 1 screw [2]  
- 1 connector [3]

---

## Chapter 4 Maintenance

---



---

# Contents

4.1 User Maintenance .....	4-1
4.1.1 User Maintenance Items .....	4-1
4.2 Maintenance and Inspection.....	4-1
4.2.1 Periodically Replaced Parts .....	4-1
4.2.1.1 Periodically Replaced Parts.....	4-1
4.2.2 Durables .....	4-1
4.2.2.1 Durables .....	4-1
4.2.3 Periodical Servicing.....	4-1
4.2.3.1 Scheduled Servicing.....	4-1
4.3 Adjustment .....	4-2
4.3.1 Basic Adjustment .....	4-2
4.3.1.1 Setting Up the Punching Operation.....	4-2
4.3.1.2 Adjusting the Sensor Light Intensity.....	4-2
4.3.1.3 Adjusting the Paper Stop Position.....	4-3
4.3.2 Auxiliary Adjustmant.....	4-4
4.3.2.1 Adjusting the Punch Hole Position (in the direction of horizontal registration).....	4-4
4.3.2.2 Adjusting the Punch Hole Position (in the direction of paper movement) .....	4-4





## 4.1 User Maintenance

### 4.1.1 User Maintenance Items

No.	Item	Timing
1	punch waste disposal	When prompted by the indicator (on the host machine control panel).

## 4.2 Maintenance and Inspection

### 4.2.1 Periodically Replaced Parts

#### 4.2.1.1 Periodically Replaced Parts

The machine does not have parts that require replacement on a periodical basis.

### 4.2.2 Durables

#### 4.2.2.1 Durables

Some parts of the machine may require replacement once or more over the period of product warranty. Replace them when necessary.

No.	Parts name	Parts No.	Q'ty	Life	Remarks
1	punch waste disposal	FM2-6391	1	1,000,000	100,000 operations if
2	Punch unit (2-/3-hole)	FM2-6392	1	punching	10% of use is for 200 g/
3	Punch unit (4-hole; French)	FM2-6393	1	operations	m2 paper
4	Punch unit (4-hole; Sweden)	FM2-6394	1		

### 4.2.3 Periodical Servicing

#### 4.2.3.1 Scheduled Servicing

Item	Interval	Task	Remarks
Punch waste case full sensor	1,000,000 prints	cleaning	dry wiping
prism	1,000,000 prints	cleaning	dry wiping

## 4.3 Adjustment

### 4.3.1 Basic Adjustment

#### 4.3.1.1 Setting Up the Punching Operation

The machine must be set to accommodate the punch unit in use by changing the setting of the DIP switch found on its switch PCB.

SW381

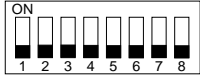

punch unit not used

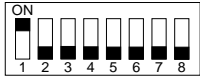

2-hole punch unit used

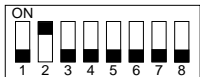

2-/3-hole punch unit used

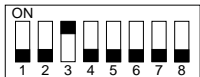

4-hole punch unit used (Sweden)

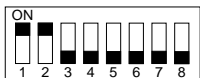

4-hole punch unit used (France)

F-4-1

#### 4.3.1.2 Adjusting the Sensor Light Intensity

Go through the following steps when installing the punch unit or when replacing the punch waste case full sensor:

- 1) Turn on the finisher.
- 2) Turn on the power switch of the host machine so that it is in a standby state.
- 3) Open the front door, and insert the door switch actuator into the door switch [1].

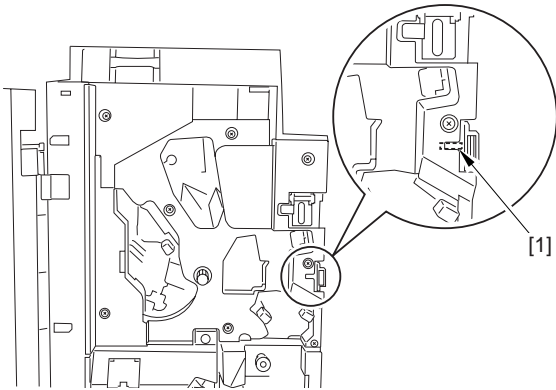

F-4-2

- 4) Insert a screwdriver [2] into the hole [1] in the bottom face of the tray, and release the tray in the direction of the arrow; then, lower the tray A/B in the direction of the arrow.

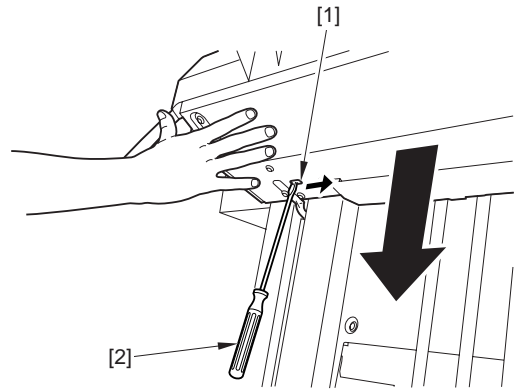

F-4-3



Be sure to move it until the tray sensor (front/rear) will not be blocked by the tray A/B [2].

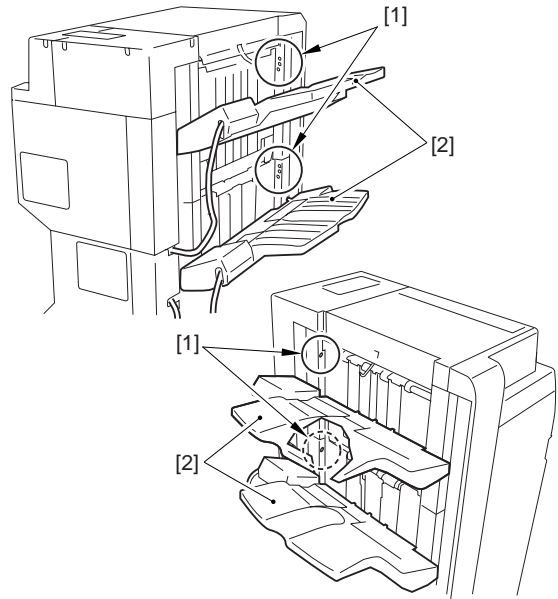

F-4-4

- 5) Remove the screw [2], and detach the switch cover [1].

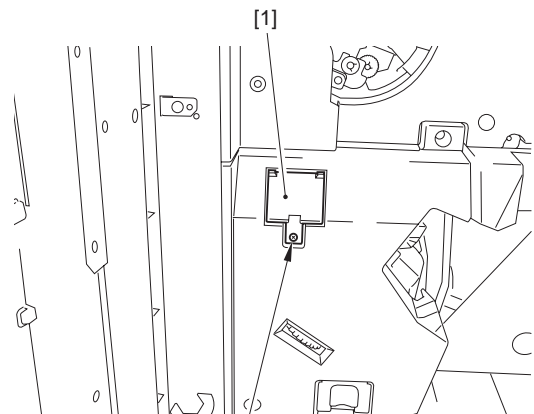

F-4-5

- 6) Set the bits of the DIP switch SW382 [1] found on the switch PCB as shown, and press the Enter button (SW385) [2] to start sensor light intensity adjustment.

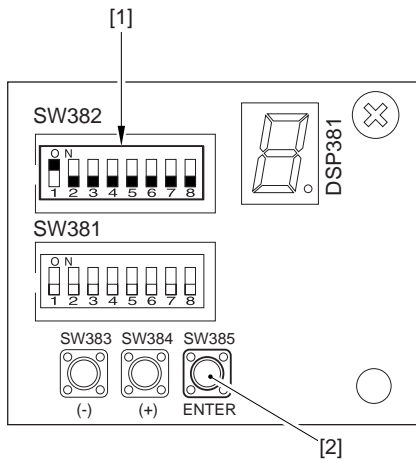

F-4-6

- 7) See if the LED [1] is '0', indicating that the adjustment has been successful; press the Enter button (SW385) [2] to end sensor light intensity adjustment. If the LED [3] flashes while indicating '0', the presence of a fault is likely.

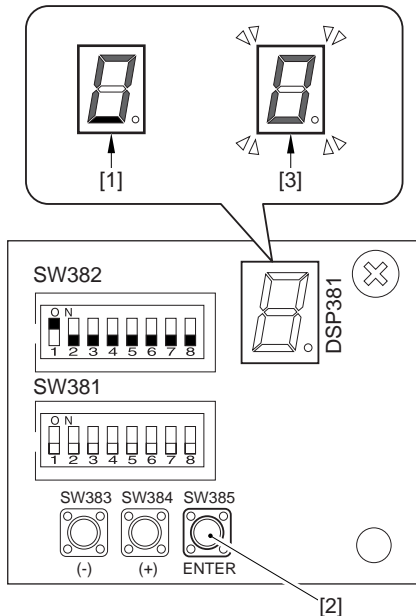

F-4-7

- 8) If there is a faulty sensor (i.e., if the LED flashes while indicating '0'), press the + (SW384) [1]/- (SW383) [2] button to find out the code No. of the sensor in question, and clean the sensor; if the fault is not solved, replace the sensor.

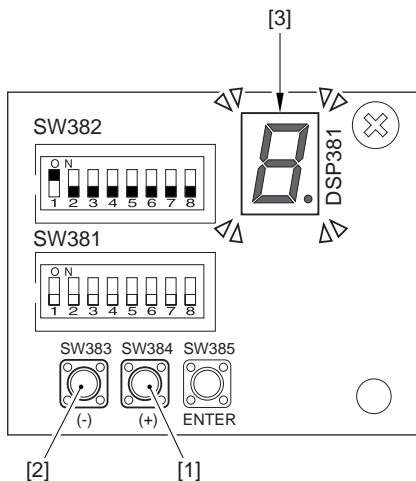

F-4-8

The sensors are identified by the following code No.:

Code No.	Sensor
1	buffer path 1 sensor PCB (UN13)
2	buffer path 2 sensor PCB (UN14)
3	lower path sensor PCB (UN24)
4	horizontal registration sensor PCB (UN12)
5	nch waste case full sensor PCB (UN21)
6 to 8	tray A paper surface sensor PCB (UN16)
9, A, b	tray B paper surface sensor PCB (UN18)

### 4.3.1.3 Adjusting the Paper Stop Position

Go through the following steps so that the distance from the center of the punch hole to the stopper is 12 mm, making sure that the paper edge angle is correct.

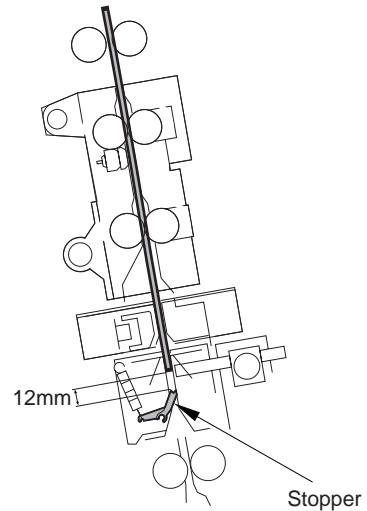

F-4-9

Go through the following for operation:

- 1) Turn on the finisher.
- 2) Turn on the power switch of the host machine so that it is in a standby state.
- 3) Open the front door, and insert the door switch actuator into the door switch [1].

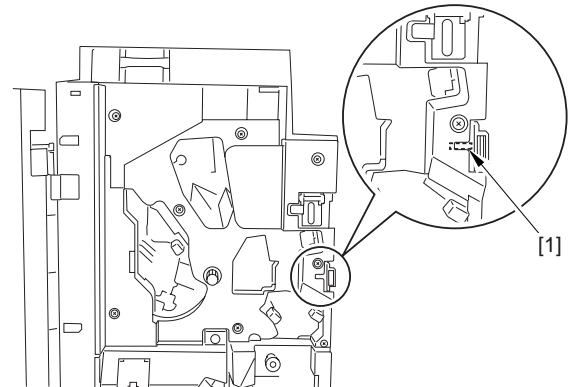

F-4-10

- 4) Remove the screw [2], and detach the switch cover [1].

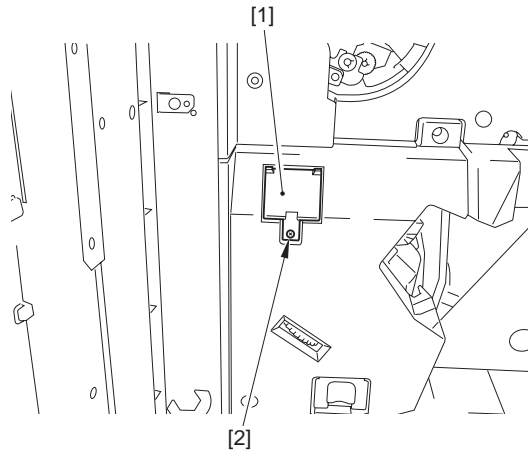

F-4-11

5) Set the DIP switch SW382 found on the switch PCB as shown, and press the Enter (SW385) button so that the LED indicates '0'.

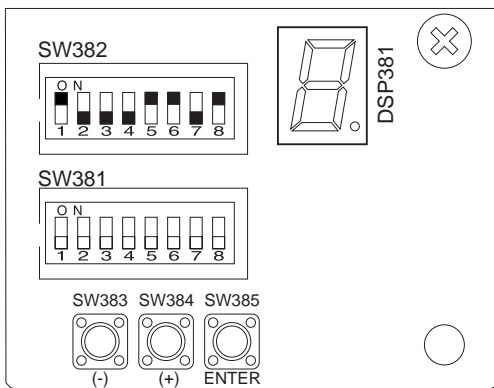

F-4-12

6) Execute punching operation so that the machine will stop the paper and punch holes without switching it back.  
 7) Measure the distance between the punched hole and the edge of the paper, checking the paper stop position based on the result. Press the + (SW384)/- (SW383) button so that the distance is as shown.

2-Hole, 4-Hole

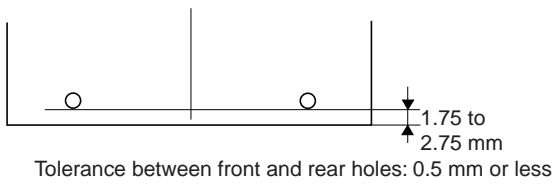

2-/3-Hole

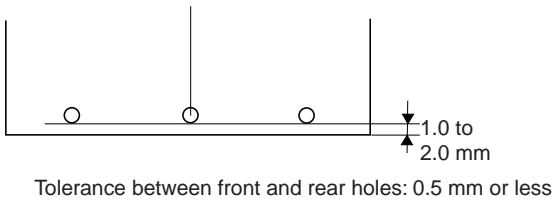

F-4-13

	Paper stop position	Adjustment value
+	raise	press once (0.4 mm)
-	lower	

8) If the result is not good, repeat the steps until satisfactory. When done, press the Enter button to end adjustment mode.

4.3.2 Auxiliary Adjustmant

4.3.2.1 Adjusting the Punch Hole Position (in the direction of horizontal registration)

Perform the following if the punch hole position is displaced in the direction of horizontal registration, possibly by paper moving askew. In the adjustment, the distance over which the horizontal registration unit and the shift roller unit moves will be adjusted.

1) Measure the position of the punched hole, and use service mode to make adjustments.

SERVICE MODE:

- CODIER> ADJUST> PNCH-Y

range of adjustment: -5 to 5 (unit: 0.45 mm)

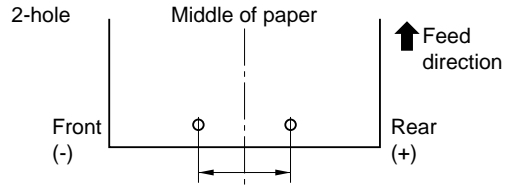

Displacement from the middle of paper is +/- 1 mm (of the center of the 2 individuals holes in front/rear direction).

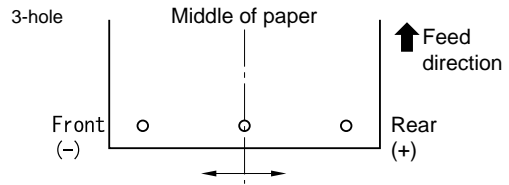

Displacement from the middle of paper is +/- 1 mm (of the center of the middle hole in front/rear direction).

F-4-14

2) If the results are not good, repeat the foregoing step until they are satisfactory.

4.3.2.2 Adjusting the Punch Hole Position (in the direction of paper movement)

Go through the following steps when raising the position of the punch hole from the standard position:

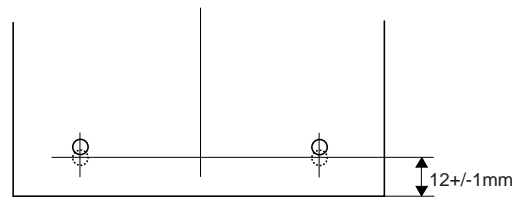

F-4-15

Go though the following for operation:

- 1) Turn off the host machine.
- 2) Turn off the finisher.
- 3) Detach the punch unit from the finisher.
- 4) Remove the punch dust guide [1].

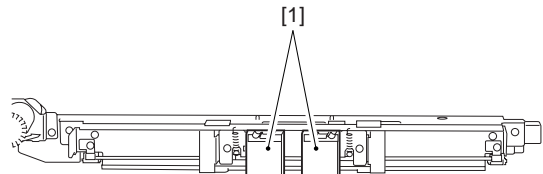

F-4-16

5) Loosen the 2 outside screws [1], and lower the 2 rear stopper support plates [2].

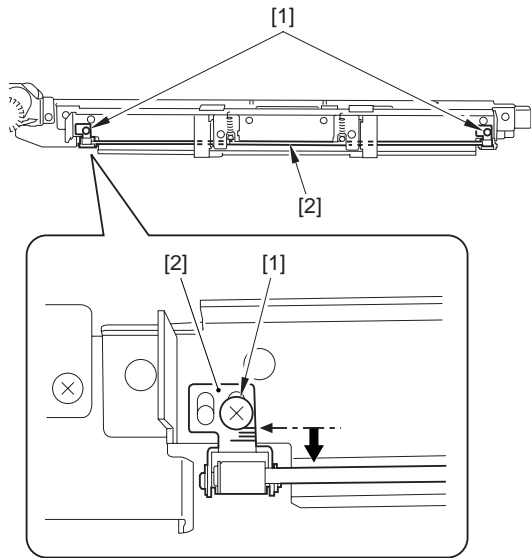

F-4-17

6) Loosen the 2 rear screws [1], and lower the 2 stopper stays [2].

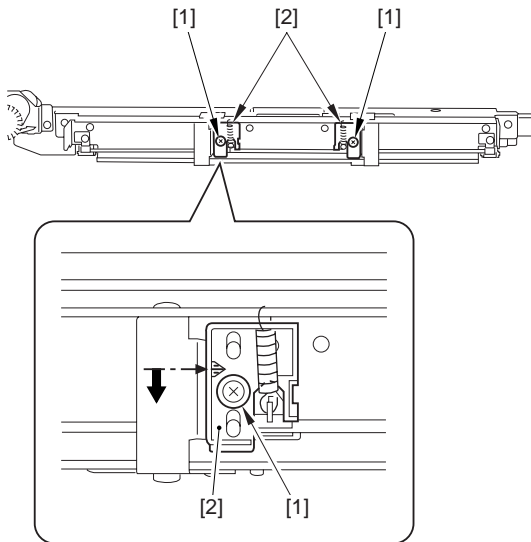

F-4-18

7) Check to see if the distance between the rear stopper support [1] and the stopper stay [2] is 1 mm or less when the puncher unit is held as when it is fitted to the finisher.

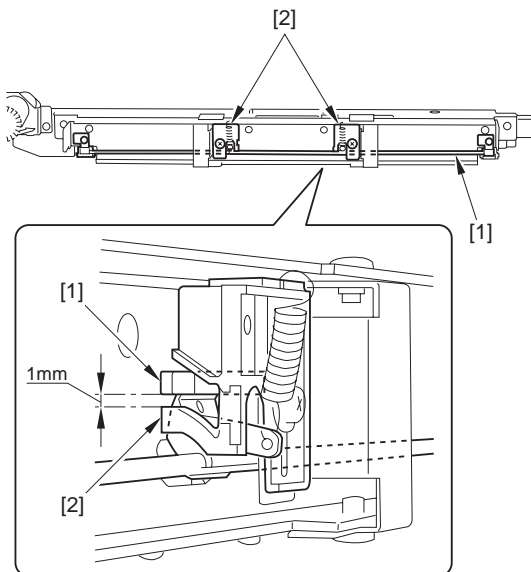

F-4-19



When done, check to make sure the rear stopper moves smoothly.

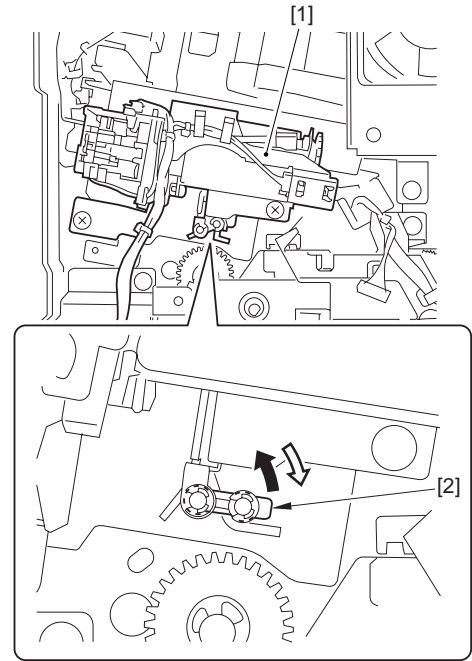

F-4-20

8) Fit the puncher unit back on the finisher, and execute punching to be sure that the punch hole position is correct.



Adjust the paper stop position in keeping with the change you made to the position of the rear stopper.



---

## Chapter 5 Error Code

---





# Contents

5.1 Overview .....	5-1
5.1.1 Overview .....	5-1
5.2 Service Error Code .....	5-1
5.2.1 E503 .....	5-1
5.2.2 E590 .....	5-1



## 5.1 Overview

### 5.1.1 Overview

The machine's finisher controller PCB is equipped with a mechanism that checks the machine condition. The PCB runs a check at such times as needed, and communicates to the host machine upon detection of a fault in the form of a code and a detail code. The host machine indicates the code in its control panel (detail code in service mode).

## 5.2 Service Error Code

### 5.2.1 E503

Code	Detail	Item	Description	Remedial action
E503	0003	finisher internal communication error	There is an error in the communication between the finisher and the punch unit.	<ol style="list-style-type: none"> <li>1. Check the cable connection between the finisher controller PCB and the punch unit.</li> <li>2. Replace the punch unit.</li> <li>3. Replace the finisher controller PCB.</li> </ol>

### 5.2.2 E590

Code	Detail	Item	Description	Remedial action
E590	8001	punch motor (M24) error	The punch home position sensor (PS36) is not detected even when the punch motor has been driven for 200 msec.	<ol style="list-style-type: none"> <li>1. Check the punch motor.</li> <li>2. Check the punch motor clock sensor (PS38).</li> <li>3. Replace the punch motor.</li> <li>4. Replace the finisher controller PCB.</li> </ol>
	8002		The punch home position sensor (PS36) is detected even after the punch motor has been driven for 200 msec.	
	8004		At the time of a 2-hole/3-hole operation switch-over, the punch motor home position sensor (PS36) is not detected.	



Feb 7 2006

**Canon**